

IMB0300

COOLING SYSTEM

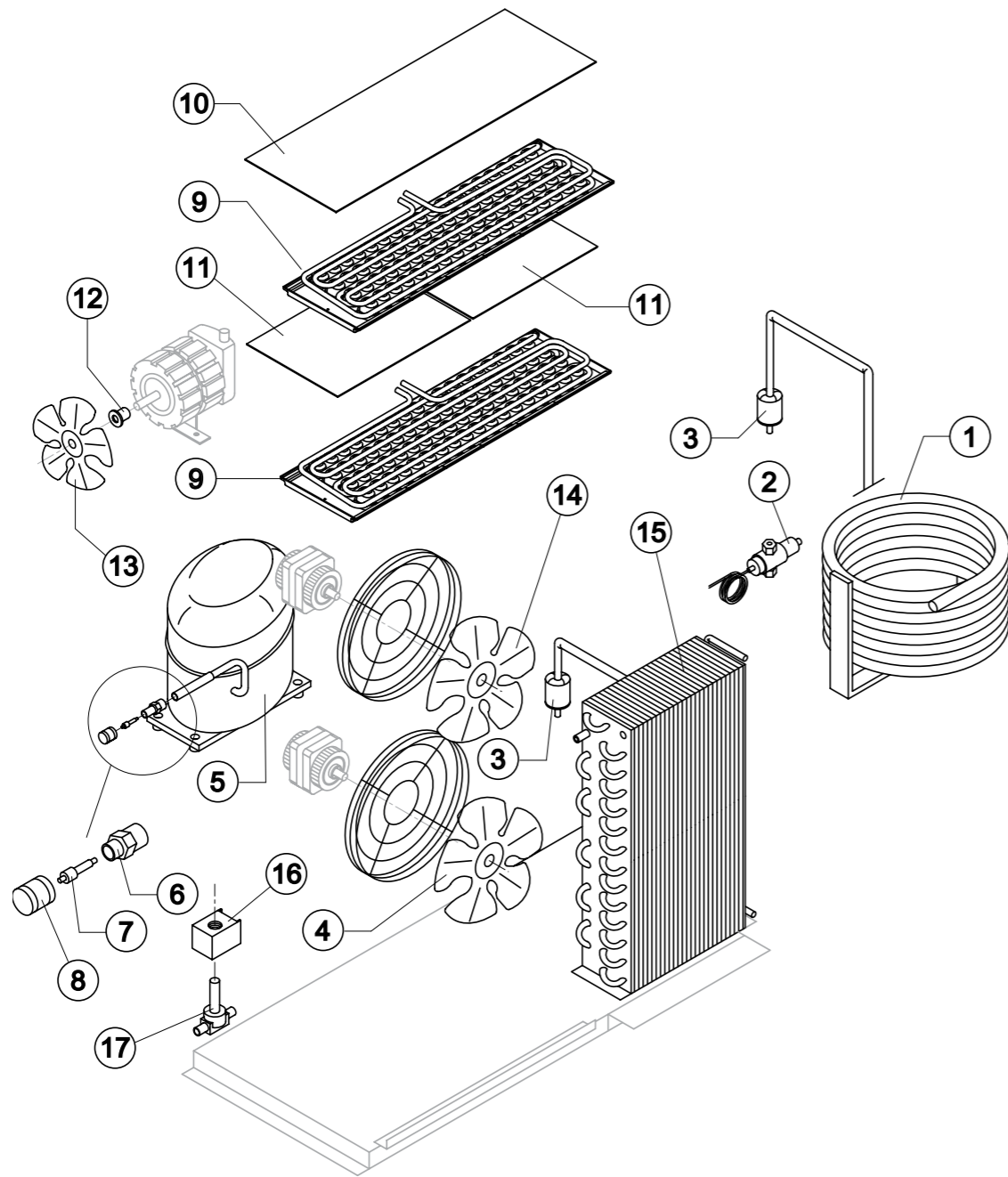

STOCK CODE	DESCRIPTION	MAN.PART NUMBER	DRAWING REF
XIMB3639	ICE MAKER BREMA-WATER CONDENSER(IMB0400/0500)	14285	1
XIMB3640	ICE MAKER BREMA-PRESSURE VALVE(IMB1400)	20149	2
XIMB8180	ICE MAKER BREMA VM500 - LIQUID LINE DRIER	14084	3
XIMB3489	ICE MAKER BREMA-(VM900A)COMPRESSOR FOR IMB0400	23489	5
XIMB3658	ICE MAKER BREMA- HUB FOR FAN (ALL)	10014	12
XIMB3657	ICE MAKER BREMA- SUCTION FAN (ALL)	10213	13
XIMB3091	ICE MAKER BREMA - (VM ALL)HOT GAS COIL	23091	16

IMB0300

HYDRAULIC CIRCUIT

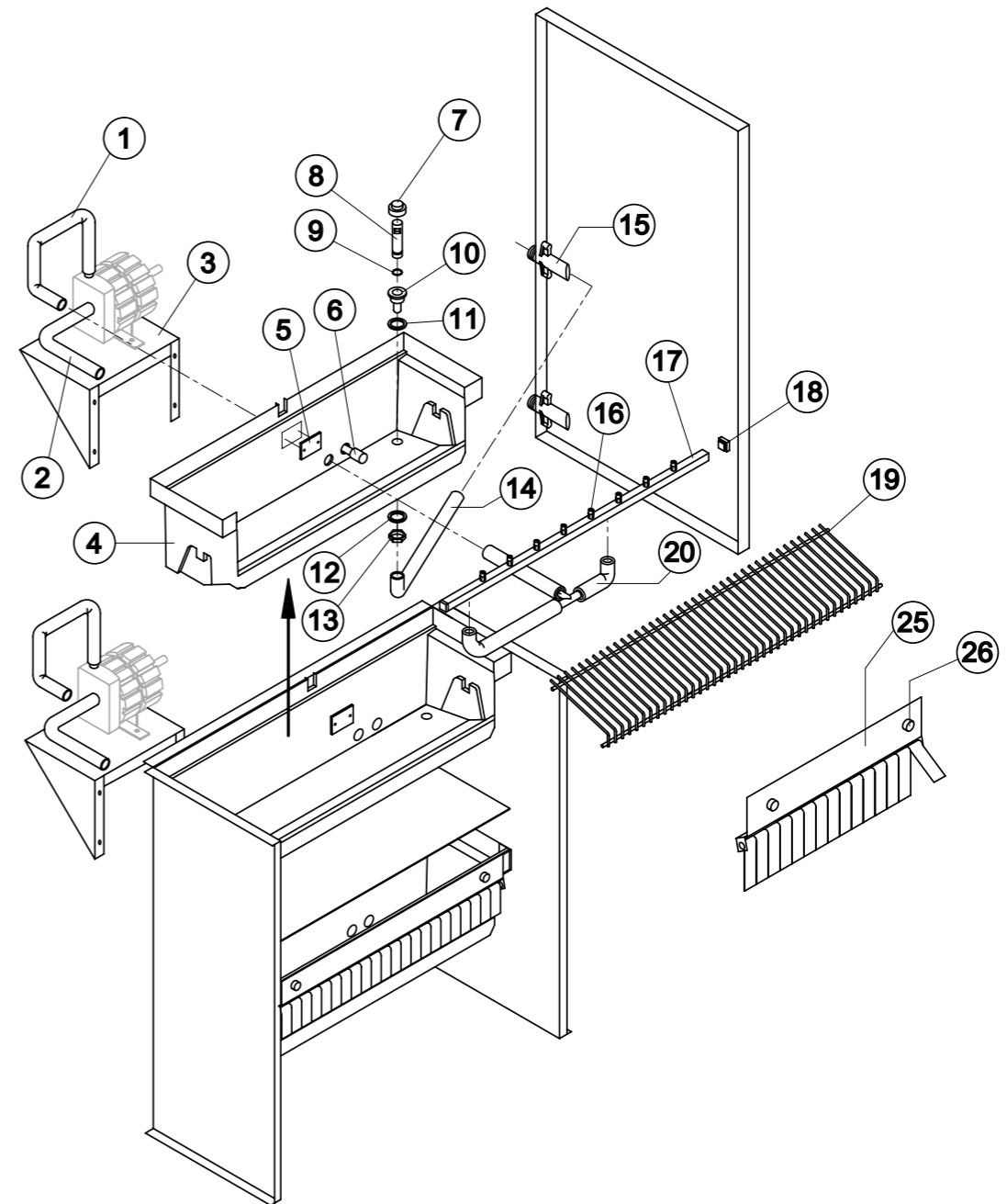

STOCK CODE	DESCRIPTION	MAN.PART NUMBER	DRAWING REF
XIMB2005	ICE MAKER BREMA - (VM) (ALL) SUCTION FILTER	20005	6
XIMB0305	ICE MAKER BREMA -(CB)(ALL) -OVERFLOW CAP	10305	7
XIMB0133	ICE MAKER BREMA -(CB)(ALL) OVERFLOW PIPE	10133	8
XIMB0233	ICE MAKER BREMA -(CB)(ALL) O' RING	20233	9
XIMB3006	ICE MAKER BREMA (CB)(ALL)SILICONE GASKET	13006	11
XIMB0002	ICE MAKER BREMA -(CB)(VM350/500) SPRAYER NOZZLES	D20002	16
XIMB3654	ICE MAKER BREMA-ICE CUBE SLIDE(IMB0130)	D12022	19
XIMB0009	ICE MAKER BREMA-(ALL) SCREW FOR SPRAYER	20009	26

ELECTRIC PARTS

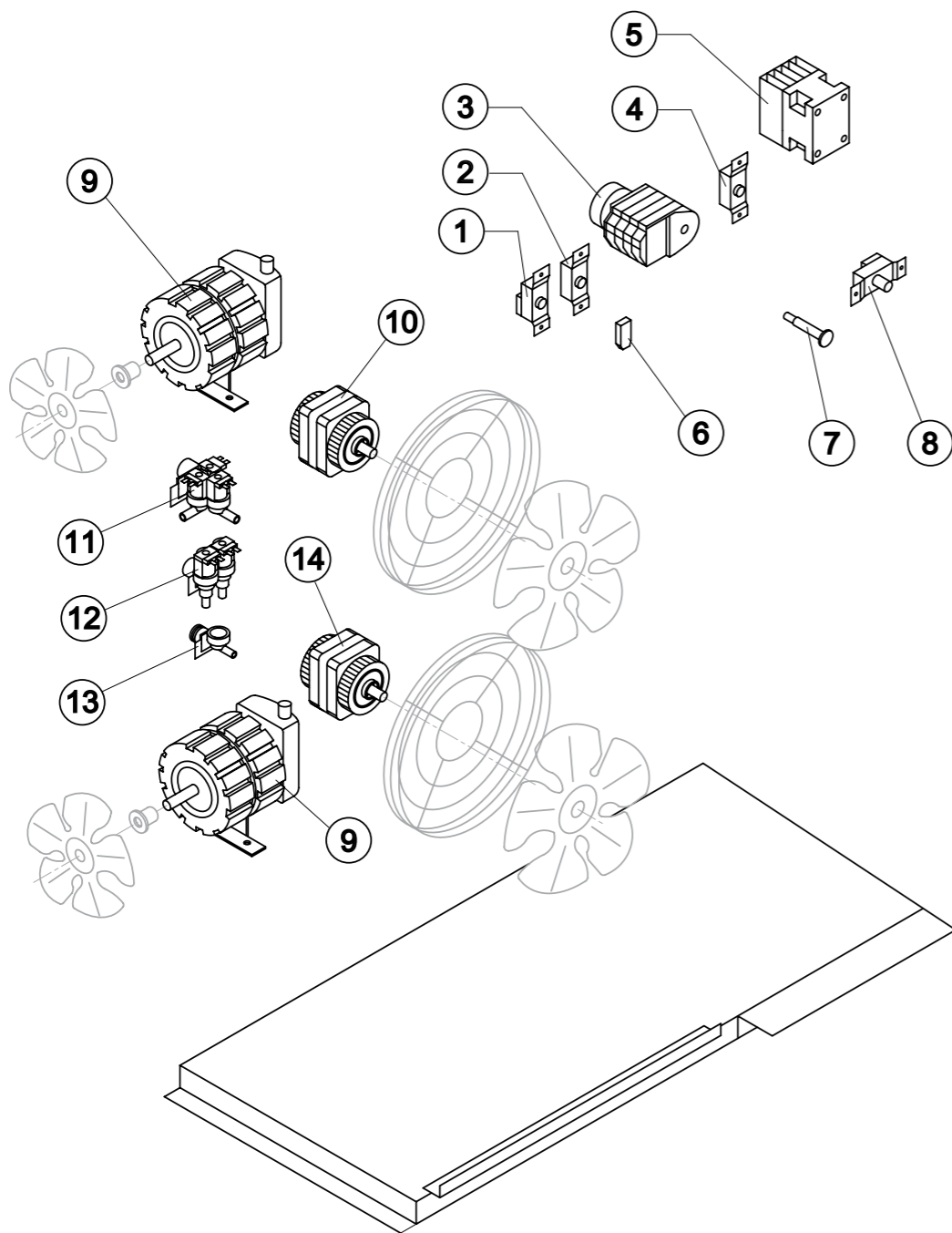

STOCK CODE	DESCRIPTION	MAN.PART NUMBER	DRAWING REF
XIMB3421	ICE MAKER BREMA -(C)(ALL) BIN THERMOSTAT	R23421	1
XIMB3591	ICE MAKER BREMA-(CB)(ALL) EVAP. THERMO	R23591	2
XIMB3646	ICE MAKER BREMA-TIMER (IMB0155)	23247	3
XIMB3647	ICE MAKER BREMA-PRESURE SWITCH (IMB0155)	23175	4
XIMB3648	ICE MAKER BREMA-220V CONTACTOR (IMB0300)	23147	5
XIMB8177	ICE MAKER BREMA - HIGH PRESSURE SAFETY SWITCH	23342	8
XIMB3121	ICE MAKER BREMA - (VM ALL)FAN MOTOR	23121	10

WIRING DIAGRAM

